

THIS DRAWING IS UNPUBLISHED. RELEASED FOR PUBLICATION, 19 .  
 © COPYRIGHT 19 BY AMP INCORPORATED. ALL INTERNATIONAL RIGHTS RESERVED.

MOD	LOC	DIST	P	F	REVISIONS			
ZONE	LTR	DESCRIPTION	DATE	APPD				
					M	REV PER OUE0-0037-01	170CT01	JR

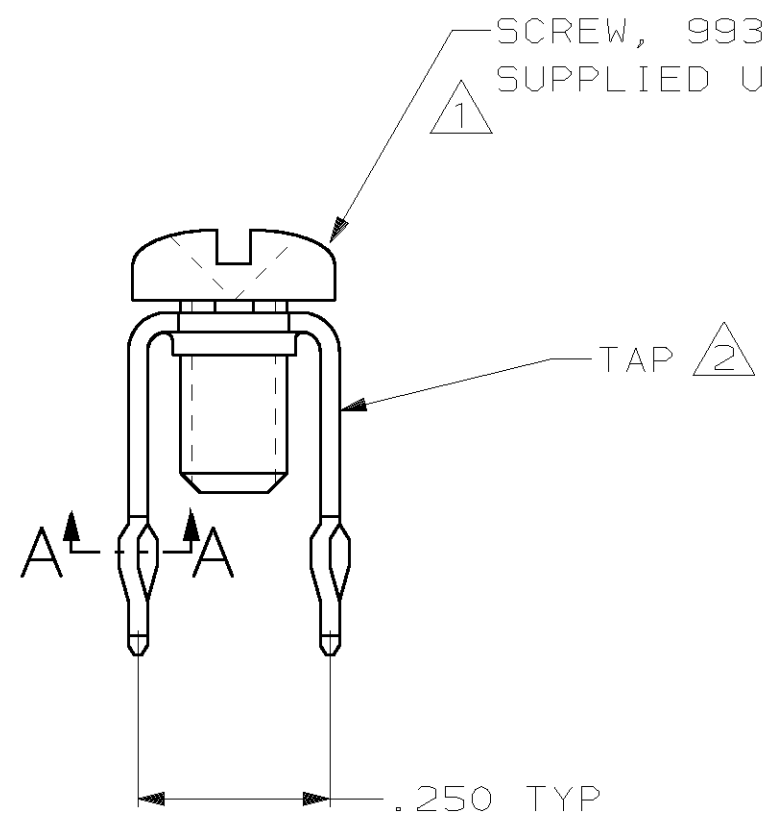
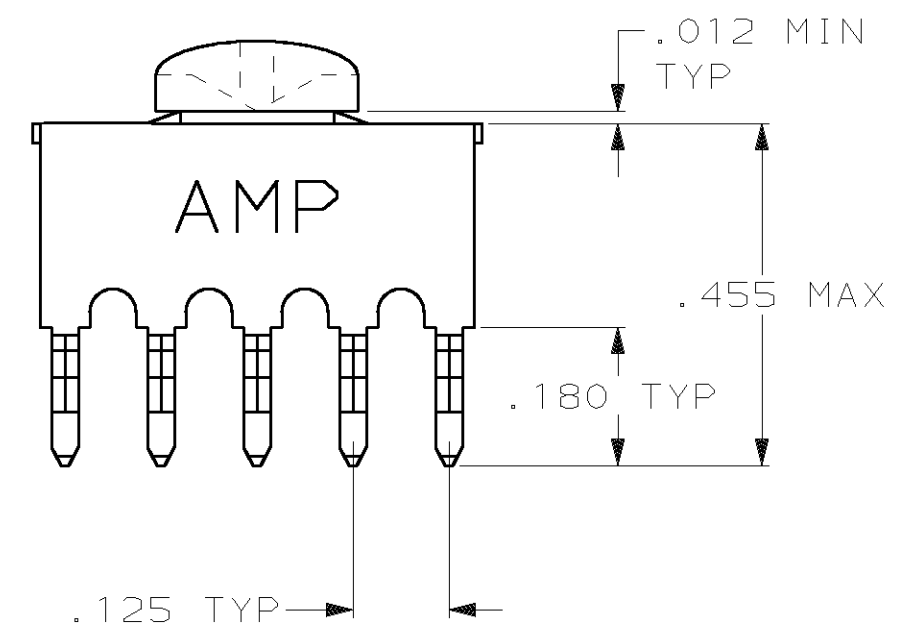
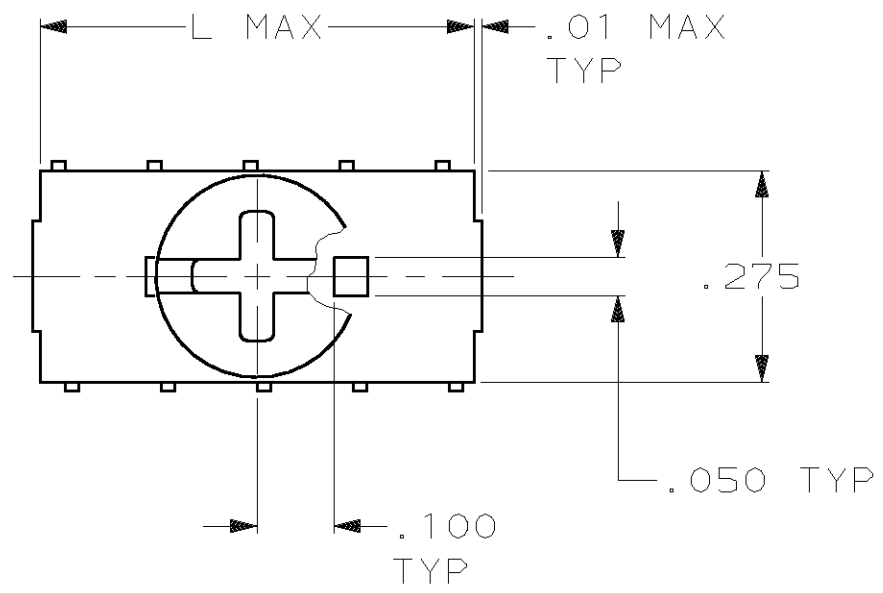

SCREW, 993879-1  
 SUPPLIED UNASSEMBLED, SEE TABLE

- 1 TO PREVENT THREAD STRIPPING, SCREW TORQUE SHOULD NOT EXCEED 9 IN LBS.
- 2 TAP HOLE IS 6-32UNC-2B, TWO MIN THREADS.
- 3 FINISH .000150 BRIGHT TIN-LEAD OVER .000050 NICKEL .

.57	YES	10	1-55323-0
.32	YES	6	55323-9
.57	NO	10	55323-6
.32	NO	6	55323-5
L	993879-1	NUMBER OF POSN	PART NO



SECTION A-A  
 SCALE 10:1  
 10 PLACES

DO NOT SCALE PRINT. UNLESS SPECIFIED DIMENSIONS IN INCHES TOLERANCES ON: 2 PLC DEC ± - 3 PLC DEC ± .008 ANGLES ± - MATERIAL COPPER ALLOY 725, .025 THICK FINISH <span style="border: 1px solid black; padding: 2px;">3</span>	DR 1-11-88 J. McCLINTON	<b>AMP</b>   AMP INCORPORATED Harrisburg, Pa. 17105	
	CHK 1-11-88 R. STONE		
	APPD 1-15-88 M. GALLOWAY	NAME TAP, POWER DISTRIBUTION	
	APPD 1-15-88 M. GALLOWAY	SIZE <b>B</b>	FSCM NO 00779
PRODUCT SPEC	APPLICATION SPEC	SCALE 4:1	SHEET 1 OF 1
WEIGHT			