

THIS DRAWING IS UNPUBLISHED. RELEASED FOR PUBLICATION
 © COPYRIGHT - By - ALL RIGHTS RESERVED.

LOC		DIST		REVISIONS					
AF		50		P	LTR	DESCRIPTION	DATE	DWN	APVD
				A1		ECR-14-012274	14AUG14	PKS	RRP

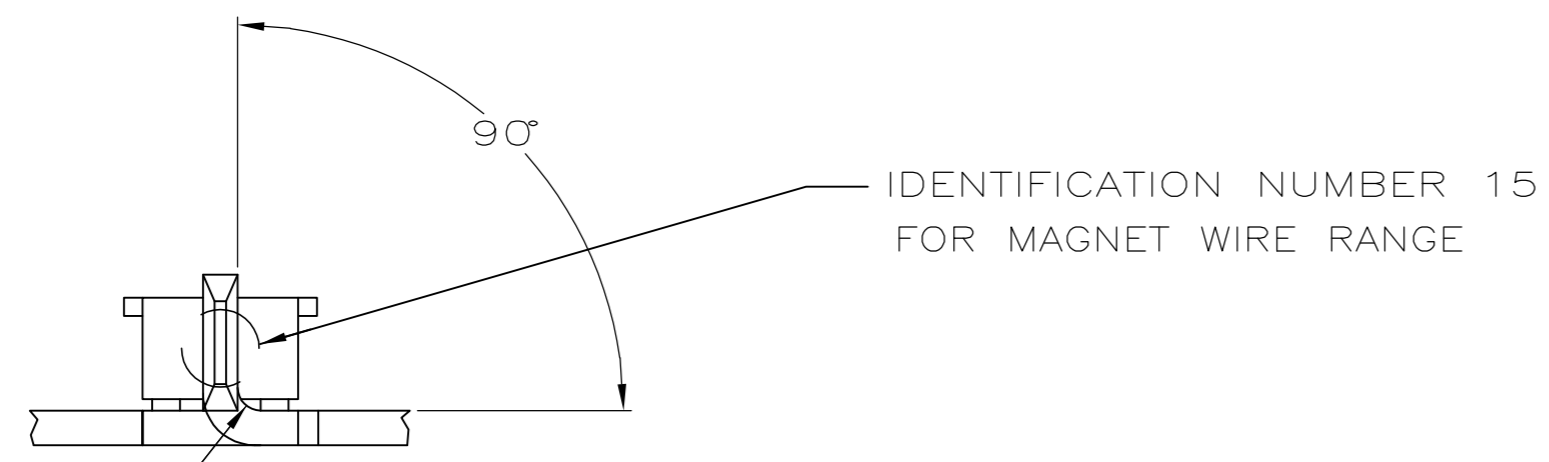

R0.51 MAX
 [.020]

- 1 CONTINUOUS STRIP ON REELS WITH TERMINALS LOCATED ON 8.38±0.076 [.330±.003] CENTERS
- 2 SLOT ACCEPTS SINGLE OR DOUBLE 0.7-0.9mm DIA [#21-19] AWG ALUMINUM MAGNET WIRE
- 3 REFER TO DWG 87-1039-3 FOR ADDITIONAL CAVITY INFORMATION (MODIFIED DEPTH)
- 4 PRE-PRODUCTION - FASR REQUIRED
- 5 0.0010 [.000040] MIN TIN PLATE

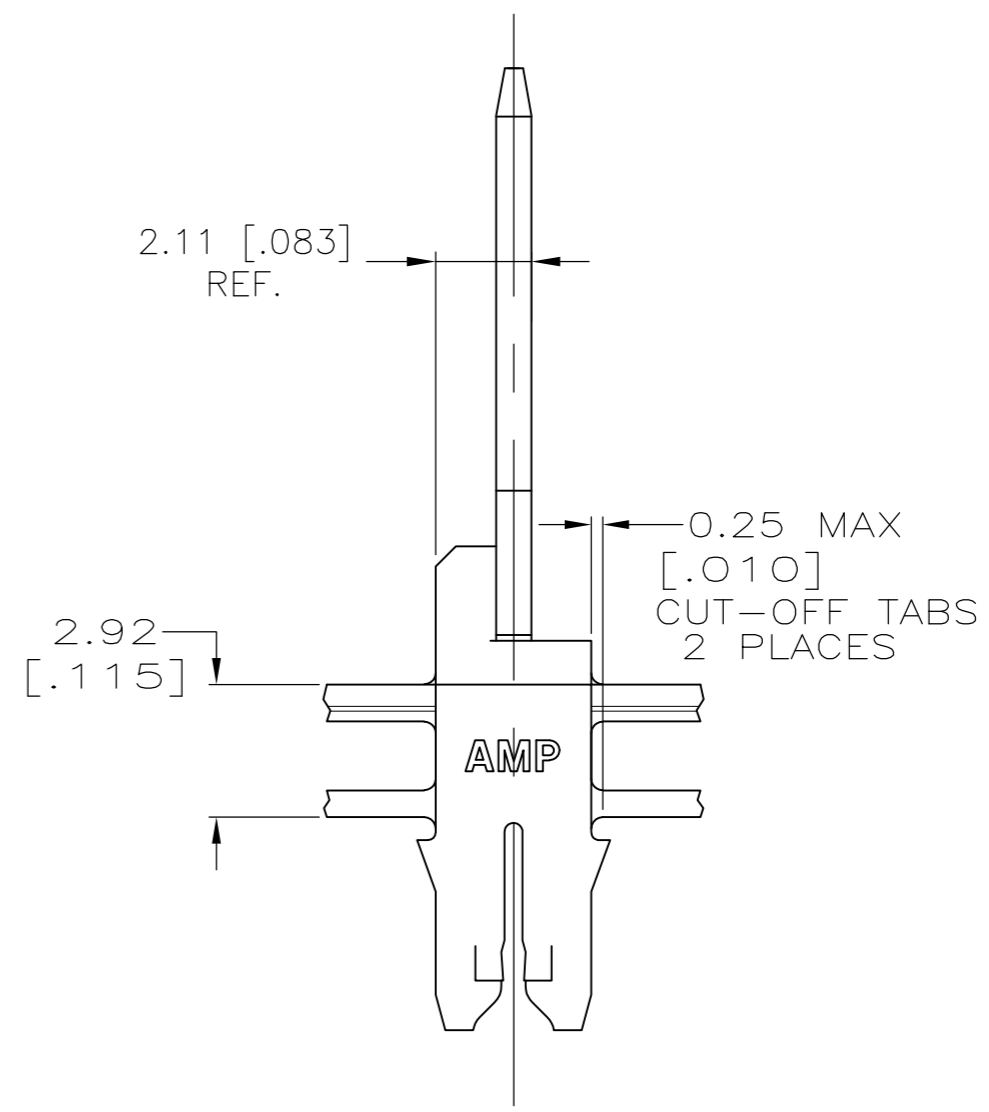
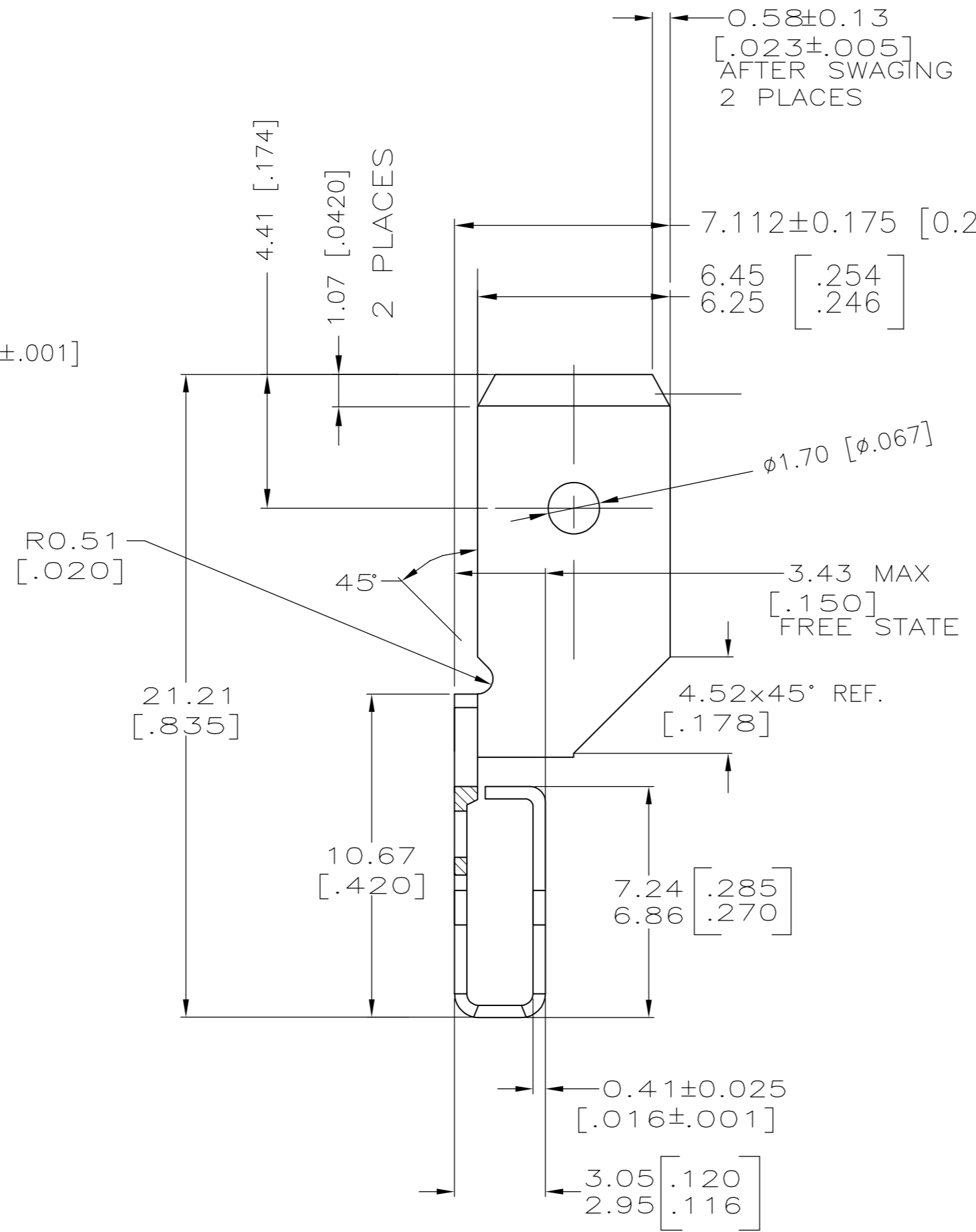
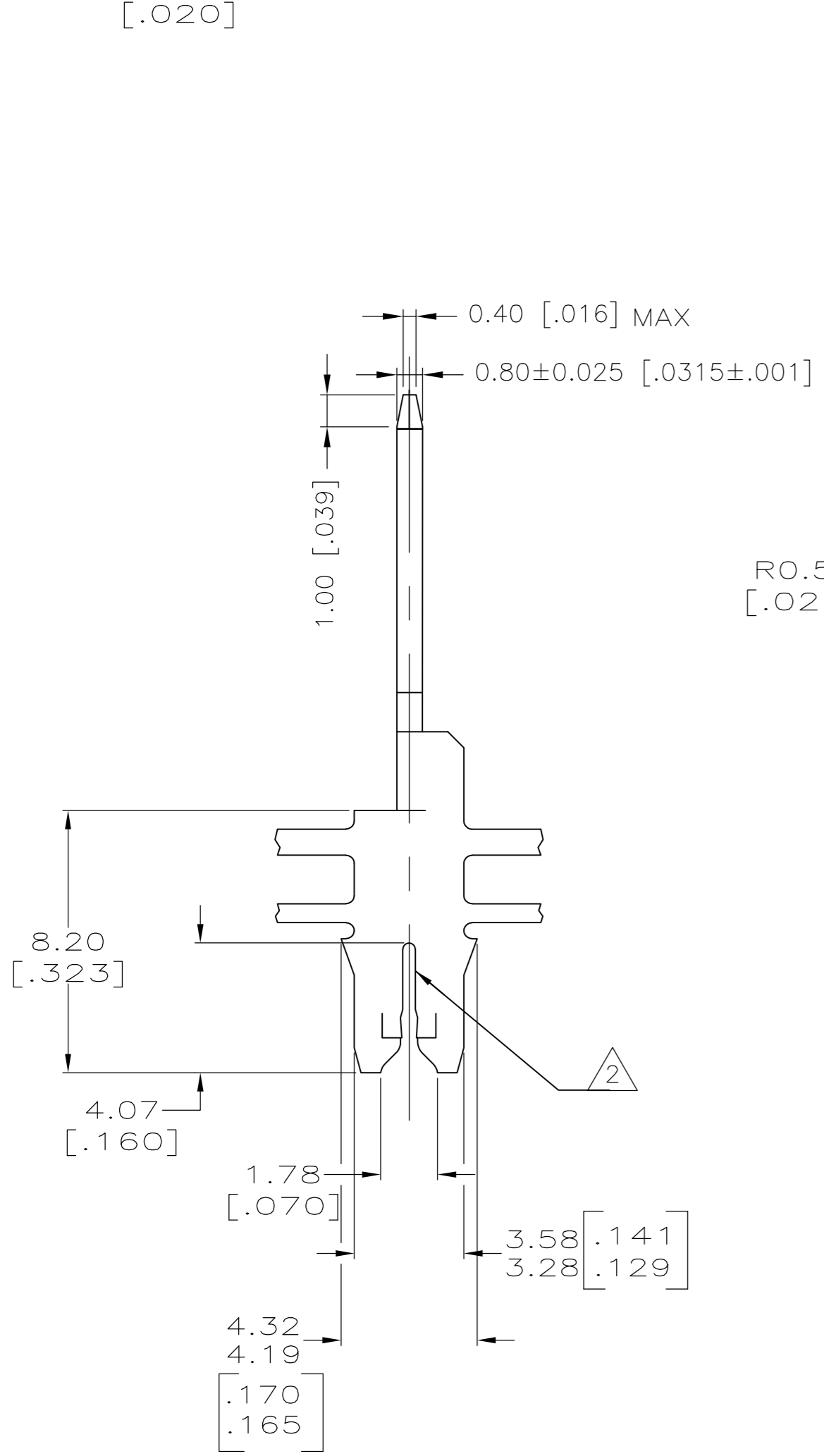

THIS DRAWING IS A CONTROLLED DOCUMENT.		DWN	R.GRZYBOWSKI	24JUN97	FINISH		WELD	2232683-1	
DIMENSIONS: mm		CHK	M.S.FEHER	24JUN97	SPLICE		PART NUMBER		
TOLERANCES UNLESS OTHERWISE SPECIFIED:		APVD	N.E.NEFF	24JUN97	NAME		TE Connectivity		
0 PLC ± -		PRODUCT SPEC	108-2012	SIZE		CAGE CODE	DRAWING NO	RESTRICTED TO	
1 PLC ± -		APPLICATION SPEC	114-2046	A2		00779	C=2232683	-	
2 PLC ± 0.25 [.010]		WEIGHT	-	SCALE		6:1	SHEET	1 of 1	
3 PLC ± -		FINISH	SEE TABLE	REV		A1			
4 PLC ± -		CUSTOMER DRAWING							
ANGLES ± 5°									